

CUSTOMER SIGNATURE: _____

DATE: _____

IN AN EFFORT TO ENSURE ACCURACY, PLEASE REVIEW YOUR DRAWING DIMENSIONS AND FITTING SIZES FOR POSSIBLE ERRORS AND OMISSIONS. CALL WITH ANY CORRECTIONS BEFORE SIGNING THIS DRAWING. ALL TANKS DESIGNED AND/OR BUILT, IN PART OR COMPLETE, BY ALUMITANK OR ANY OF ITS PEOPLE ARE CERTIFIED FOR USE ONLY WITH DISTILLATE, HYDRAULIC, OR WATER. ANY VARIATIONS OF USE OR MODIFICATIONS OF THE TANK ARE PROHIBITED. CUSTOMER SIGNATURE ON DOCUMENT/DRAWING INDICATES AGREEMENT BY SIGNER OR RECIPIENT OF TANK AND HOLDS ALUMITANK HARMLESS.

CUSTOMER NAME:

SIDE OF TRUCK:

SHOP #:

PARTS:

FINISH:

CAPACITY:

SERIAL #:

CHASSIS STYLE:

SHIP DATE:

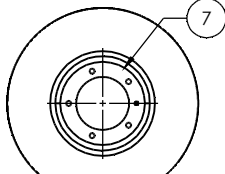
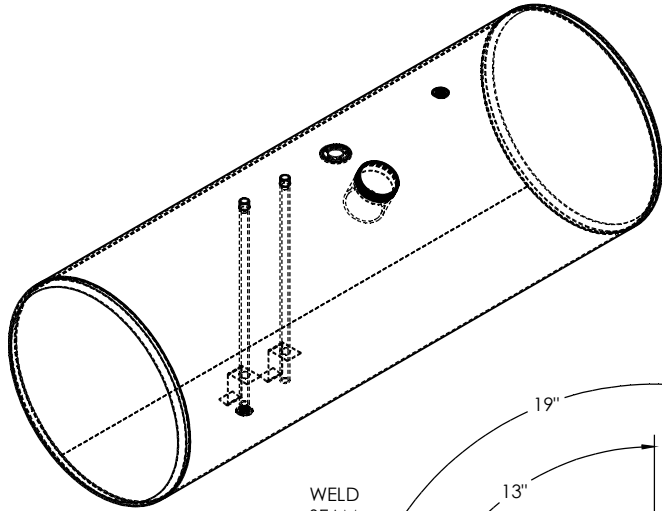

DETAIL A
SCALE 1 : 3

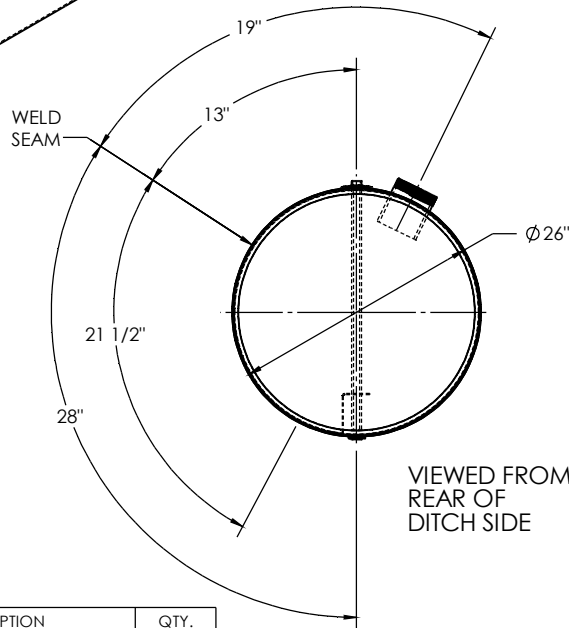

VIEWED FROM
REAR OF
DITCH SIDE

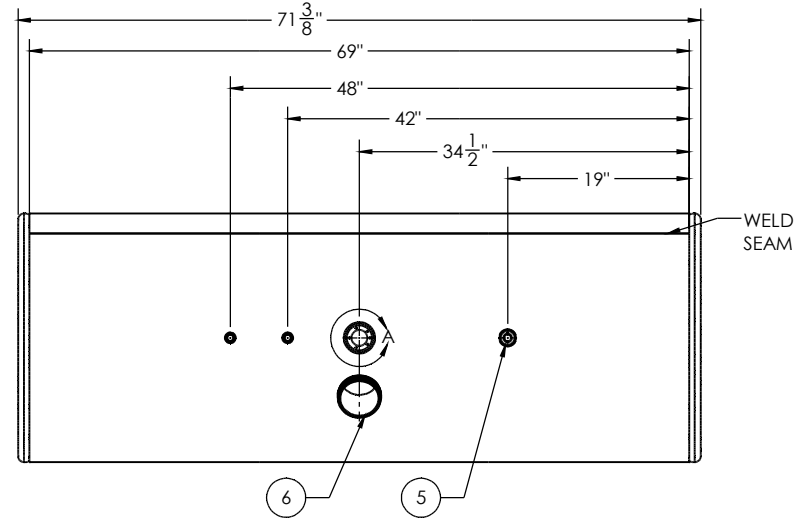

TRUCK FRONT
DITCH SIDE

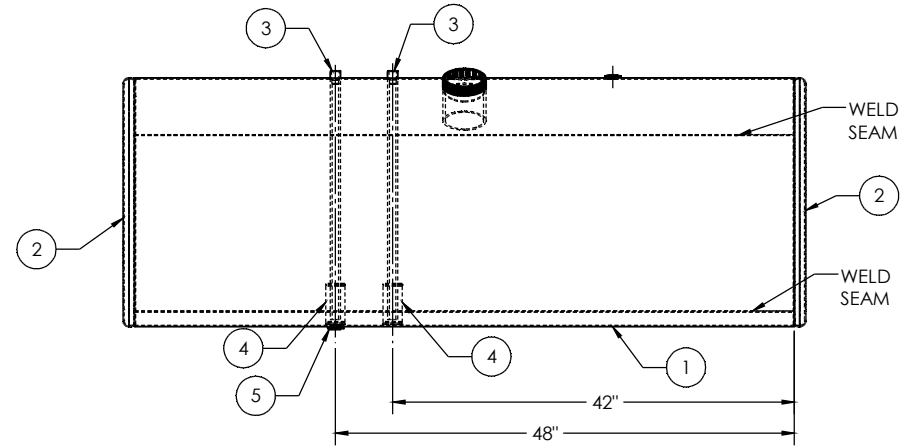

ITEM NO.	PART NUMBER	DESCRIPTION	QTY.
1	BRL-119479	1/8" TANK BARREL	1
2	ECP-4160013100	26" POLISHED ALUMINUM END CAP	2
3	TBS-503200	1/2" NPTF TUBE	2
4	STR-001	SMALL TUBE STABILIZER	2
5	FLG-050230	1/2" NPTF POLISHED ALUMINUM FLANGE	2
6	FLN-0801412310	5" LONG - 4" NPSM - 8 TPI POLISHED ALUMINUM FILL NECK	1
7	BSE-00183220	CURVED POLISHED ALUMINUM SENDER BASE	1

TITLE:		UNLESS OTHERWISE SPECIFIED:		NAME	DATE		
SIZE C	REV	QC	INITIALS	DRAWN			
		PSI		CHECKED			
		DIMS		ENG APPR.			
		PARTS		MFG APPR.			
	TAG			D.A.			
	PKG			COMMENTS:			
<small> PROPRIETARY AND CONFIDENTIAL THE INFORMATION CONTAINED IN THIS DRAWING IS THE SOLE PROPERTY OF ALUMITANK. ANY REPRODUCTION IN PART OR AS A WHOLE WITHOUT THE WRITTEN PERMISSION OF ALUMITANK IS PROHIBITED. </small>		<small> DIMENSIONS ARE IN INCHES FRACTIONS: 1/8" 1/4" 3/8" 1/2" 5/8" 3/4" 7/8" 1" 1 1/8" 1 1/4" 1 3/8" 1 1/2" 1 5/8" 1 3/4" 1 7/8" 2" 2 1/8" 2 1/4" 2 3/8" 2 1/2" 2 5/8" 2 3/4" 2 7/8" 3" 3 1/8" 3 1/4" 3 3/8" 3 1/2" 3 5/8" 3 3/4" 3 7/8" 4" 4 1/8" 4 1/4" 4 3/8" 4 1/2" 4 5/8" 4 3/4" 4 7/8" 5" 5 1/8" 5 1/4" 5 3/8" 5 1/2" 5 5/8" 5 3/4" 5 7/8" 6" 6 1/8" 6 1/4" 6 3/8" 6 1/2" 6 5/8" 6 3/4" 6 7/8" 7" 7 1/8" 7 1/4" 7 3/8" 7 1/2" 7 5/8" 7 3/4" 7 7/8" 8" 8 1/8" 8 1/4" 8 3/8" 8 1/2" 8 5/8" 8 3/4" 8 7/8" 9" 9 1/8" 9 1/4" 9 3/8" 9 1/2" 9 5/8" 9 3/4" 9 7/8" 10" 10 1/8" 10 1/4" 10 3/8" 10 1/2" 10 5/8" 10 3/4" 10 7/8" 11" 11 1/8" 11 1/4" 11 3/8" 11 1/2" 11 5/8" 11 3/4" 11 7/8" 12" 12 1/8" 12 1/4" 12 3/8" 12 1/2" 12 5/8" 12 3/4" 12 7/8" 13" 13 1/8" 13 1/4" 13 3/8" 13 1/2" 13 5/8" 13 3/4" 13 7/8" 14" 14 1/8" 14 1/4" 14 3/8" 14 1/2" 14 5/8" 14 3/4" 14 7/8" 15" 15 1/8" 15 1/4" 15 3/8" 15 1/2" 15 5/8" 15 3/4" 15 7/8" 16" 16 1/8" 16 1/4" 16 3/8" 16 1/2" 16 5/8" 16 3/4" 16 7/8" 17" 17 1/8" 17 1/4" 17 3/8" 17 1/2" 17 5/8" 17 3/4" 17 7/8" 18" 18 1/8" 18 1/4" 18 3/8" 18 1/2" 18 5/8" 18 3/4" 18 7/8" 19" 19 1/8" 19 1/4" 19 3/8" 19 1/2" 19 5/8" 19 3/4" 19 7/8" 20" 20 1/8" 20 1/4" 20 3/8" 20 1/2" 20 5/8" 20 3/4" 20 7/8" 21" 21 1/8" 21 1/4" 21 3/8" 21 1/2" 21 5/8" 21 3/4" 21 7/8" 22" 22 1/8" 22 1/4" 22 3/8" 22 1/2" 22 5/8" 22 3/4" 22 7/8" 23" 23 1/8" 23 1/4" 23 3/8" 23 1/2" 23 5/8" 23 3/4" 23 7/8" 24" 24 1/8" 24 1/4" 24 3/8" 24 1/2" 24 5/8" 24 3/4" 24 7/8" 25" 25 1/8" 25 1/4" 25 3/8" 25 1/2" 25 5/8" 25 3/4" 25 7/8" 26" 26 1/8" 26 1/4" 26 3/8" 26 1/2" 26 5/8" 26 3/4" 26 7/8" 27" 27 1/8" 27 1/4" 27 3/8" 27 1/2" 27 5/8" 27 3/4" 27 7/8" 28" 28 1/8" 28 1/4" 28 3/8" 28 1/2" 28 5/8" 28 3/4" 28 7/8" 29" 29 1/8" 29 1/4" 29 3/8" 29 1/2" 29 5/8" 29 3/4" 29 7/8" 30" 30 1/8" 30 1/4" 30 3/8" 30 1/2" 30 5/8" 30 3/4" 30 7/8" 31" 31 1/8" 31 1/4" 31 3/8" 31 1/2" 31 5/8" 31 3/4" 31 7/8" 32" 32 1/8" 32 1/4" 32 3/8" 32 1/2" 32 5/8" 32 3/4" 32 7/8" 33" 33 1/8" 33 1/4" 33 3/8" 33 1/2" 33 5/8" 33 3/4" 33 7/8" 34" 34 1/8" 34 1/4" 34 3/8" 34 1/2" 34 5/8" 34 3/4" 34 7/8" 35" 35 1/8" 35 1/4" 35 3/8" 35 1/2" 35 5/8" 35 3/4" 35 7/8" 36" 36 1/8" 36 1/4" 36 3/8" 36 1/2" 36 5/8" 36 3/4" 36 7/8" 37" 37 1/8" 37 1/4" 37 3/8" 37 1/2" 37 5/8" 37 3/4" 37 7/8" 38" 38 1/8" 38 1/4" 38 3/8" 38 1/2" 38 5/8" 38 3/4" 38 7/8" 39" 39 1/8" 39 1/4" 39 3/8" 39 1/2" 39 5/8" 39 3/4" 39 7/8" 40" 40 1/8" 40 1/4" 40 3/8" 40 1/2" 40 5/8" 40 3/4" 40 7/8" 41" 41 1/8" 41 1/4" 41 3/8" 41 1/2" 41 5/8" 41 3/4" 41 7/8" 42" 42 1/8" 42 1/4" 42 3/8" 42 1/2" 42 5/8" 42 3/4" 42 7/8" 43" 43 1/8" 43 1/4" 43 3/8" 43 1/2" 43 5/8" 43 3/4" 43 7/8" 44" 44 1/8" 44 1/4" 44 3/8" 44 1/2" 44 5/8" 44 3/4" 44 7/8" 45" 45 1/8" 45 1/4" 45 3/8" 45 1/2" 45 5/8" 45 3/4" 45 7/8" 46" 46 1/8" 46 1/4" 46 3/8" 46 1/2" 46 5/8" 46 3/4" 46 7/8" 47" 47 1/8" 47 1/4" 47 3/8" 47 1/2" 47 5/8" 47 3/4" 47 7/8" 48" 48 1/8" 48 1/4" 48 3/8" 48 1/2" 48 5/8" 48 3/4" 48 7/8" 49" 49 1/8" 49 1/4" 49 3/8" 49 1/2" 49 5/8" 49 3/4" 49 7/8" 50" 50 1/8" 50 1/4" 50 3/8" 50 1/2" 50 5/8" 50 3/4" 50 7/8" 51" 51 1/8" 51 1/4" 51 3/8" 51 1/2" 51 5/8" 51 3/4" 51 7/8" 52" 52 1/8" 52 1/4" 52 3/8" 52 1/2" 52 5/8" 52 3/4" 52 7/8" 53" 53 1/8" 53 1/4" 53 3/8" 53 1/2" 53 5/8" 53 3/4" 53 7/8" 54" 54 1/8" 54 1/4" 54 3/8" 54 1/2" 54 5/8" 54 3/4" 54 7/8" 55" 55 1/8" 55 1/4" 55 3/8" 55 1/2" 55 5/8" 55 3/4" 55 7/8" 56" 56 1/8" 56 1/4" 56 3/8" 56 1/2" 56 5/8" 56 3/4" 56 7/8" 57" 57 1/8" 57 1/4" 57 3/8" 57 1/2" 57 5/8" 57 3/4" 57 7/8" 58" 58 1/8" 58 1/4" 58 3/8" 58 1/2" 58 5/8" 58 3/4" 58 7/8" 59" 59 1/8" 59 1/4" 59 3/8" 59 1/2" 59 5/8" 59 3/4" 59 7/8" 60" 60 1/8" 60 1/4" 60 3/8" 60 1/2" 60 5/8" 60 3/4" 60 7/8" 61" 61 1/8" 61 1/4" 61 3/8" 61 1/2" 61 5/8" 61 3/4" 61 7/8" 62" 62 1/8" 62 1/4" 62 3/8" 62 1/2" 62 5/8" 62 3/4" 62 7/8" 63" 63 1/8" 63 1/4" 63 3/8" 63 1/2" 63 5/8" 63 3/4" 63 7/8" 64" 64 1/8" 64 1/4" 64 3/8" 64 1/2" 64 5/8" 64 3/4" 64 7/8" 65" 65 1/8" 65 1/4" 65 3/8" 65 1/2" 65 5/8" 65 3/4" 65 7/8" 66" 66 1/8" 66 1/4" 66 3/8" 66 1/2" 66 5/8" 66 3/4" 66 7/8" 67" 67 1/8" 67 1/4" 67 3/8" 67 1/2" 67 5/8" 67 3/4" 67 7/8" 68" 68 1/8" 68 1/4" 68 3/8" 68 1/2" 68 5/8" 68 3/4" 68 7/8" 69" 69 1/8" 69 1/4" 69 3/8" 69 1/2" 69 5/8" 69 3/4" 69 7/8" 70" 70 1/8" 70 1/4" 70 3/8" 70 1/2" 70 5/8" 70 3/4" 70 7/8" 71" 71 1/8" 71 1/4" 71 3/8" 71 1/2" 71 5/8" 71 3/4" 71 7/8" 72" 72 1/8" 72 1/4" 72 3/8" 72 1/2" 72 5/8" 72 3/4" 72 7/8" 73" 73 1/8" 73 1/4" 73 3/8" 73 1/2" 73 5/8" 73 3/4" 73 7/8" 74" 74 1/8" 74 1/4" 74 3/8" 74 1/2" 74 5/8" 74 3/4" 74 7/8" 75" 75 1/8" 75 1/4" 75 3/8" 75 1/2" 75 5/8" 75 3/4" 75 7/8" 76" 76 1/8" 76 1/4" 76 3/8" 76 1/2" 76 5/8" 76 3/4" 76 7/8" 77" 77 1/8" 77 1/4" 77 3/8" 77 1/2" 77 5/8" 77 3/4" 77 7/8" 78" 78 1/8" 78 1/4" 78 3/8" 78 1/2" 78 5/8" 78 3/4" 78 7/8" 79" 79 1/8" 79 1/4" 79 3/8" 79 1/2" 79 5/8" 79 3/4" 79 7/8" 80" 80 1/8" 80 1/4" 80 3/8" 80 1/2" 80 5/8" 80 3/4" 80 7/8" 81" 81 1/8" 81 1/4" 81 3/8" 81 1/2" 81 5/8" 81 3/4" 81 7/8" 82" 82 1/8" 82 1/4" 82 3/8" 82 1/2" 82 5/8" 82 3/4" 82 7/8" 83" 83 1/8" 83 1/4" 83 3/8" 83 1/2" 83 5/8" 83 3/4" 83 7/8" 84" 84 1/8" 84 1/4" 84 3/8" 84 1/2" 84 5/8" 84 3/4" 84 7/8" 85" 85 1/8" 85 1/4" 85 3/8" 85 1/2" 85 5/8" 85 3/4" 85 7/8" 86" 86 1/8" 86 1/4" 86 3/8" 86 1/2" 86 5/8" 86 3/4" 86 7/8" 87" 87 1/8" 87 1/4" 87 3/8" 87 1/2" 87 5/8" 87 3/4" 87 7/8" 88" 88 1/8" 88 1/4" 88 3/8" 88 1/2" 88 5/8" 88 3/4" 88 7/8" 89" 89 1/8" 89 1/4" 89 3/8" 89 1/2" 89 5/8" 89 3/4" 89 7/8" 90" 90 1/8" 90 1/4" 90 3/8" 90 1/2" 90 5/8" 90 3/4" 90 7/8" 91" 91 1/8" 91 1/4" 91 3/8" 91 1/2" 91 5/8" 91 3/4" 91 7/8" 92" 92 1/8" 92 1/4" 92 3/8" 92 1/2" 92 5/8" 92 3/4" 92 7/8" 93" 93 1/8" 93 1/4" 93 3/8" 93 1/2" 93 5/8" 93 3/4" 93 7/8" 94" 94 1/8" 94 1/4" 94 3/8" 94 1/2" 94 5/8" 94 3/4" 94 7/8" 95" 95 1/8" 95 1/4" 95 3/8" 95 1/2" 95 5/8" 95 3/4" 95 7/8" 96" 96 1/8" 96 1/4" 96 3/8" 96 1/2" 96 5/8" 96 3/4" 96 7/8" 97" 97 1/8" 97 1/4" 97 3/8" 97 1/2" 97 5/8" 97 3/4" 97 7/8" 98" 98 1/8" 98 1/4" 98 3/8" 98 1/2" 98 5/8" 98 3/4" 98 7/8" 99" 99 1/8" 99 1/4" 99 3/8" 99 1/2" 99 5/8" 99 3/4" 99 7/8" 100" 100 1/8" 100 1/4" 100 3/8" 100 1/2" 100 5/8" 100 3/4" 100 7/8" </small>		MATERIAL: 5052 H32 ALUMINUM FINISH: SEE BOM DO NOT SCALE DRAWING		11317 N. US HWY 14 HARVARD, IL 60033 815-943-6649 800-652-6630 FAX 855-774-6918 WWW.ALUMITANK.COM INFO@ALUMITANK.COM	
DWG. NO.		119479		SCALE: 1:10 WEIGHT: SHEET 1 OF 1			