

CUSTOMER SIGNATURE: _____

DATE: _____

IN AN EFFORT TO ENSURE ACCURACY, PLEASE REVIEW YOUR DRAWING DIMENSIONS AND FITTING SIZES FOR POSSIBLE ERRORS AND OMISSIONS. CALL WITH ANY CORRECTIONS BEFORE SIGNING THIS DRAWING. ALL TANKS DESIGNED AND/OR BUILT, IN PART OR COMPLETE, BY ALUMITANK OR ANY OF ITS PEOPLE ARE CERTIFIED FOR USE ONLY WITH DISTILLATE, HYDRAULIC, OR WATER. ANY VARIATIONS OF USE OR MODIFICATIONS OF THE TANK ARE PROHIBITED. CUSTOMER SIGNATURE ON DOCUMENT/DRAWING INDICATES AGREEMENT BY SIGNER OR RECIPIENT OF TANK AND HOLDS ALUMITANK HARMLESS.

CUSTOMER NAME: _____

SIDE OF TRUCK: _____

SHOP #: _____

PARTS: _____

FINISH: _____

CAPACITY: _____

SERIAL #: _____

CHASSIS STYLE: _____

SHIP DATE: _____

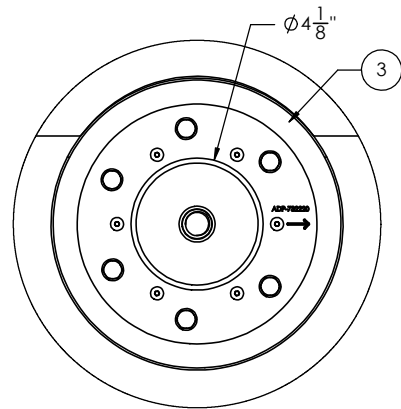

DETAIL A
SCALE 1 : 3
GASKET REMOVED
FOR CLARITY

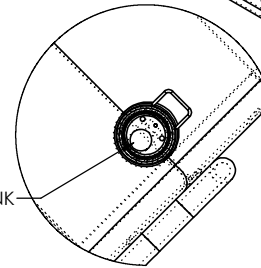
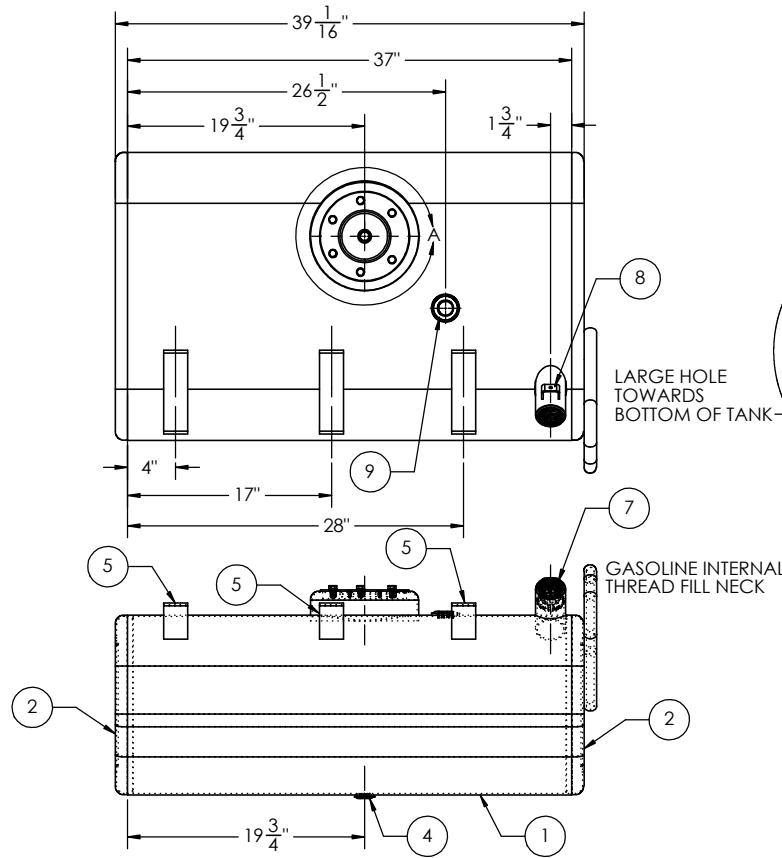

VIEW C-C
SCALE 1 : 4

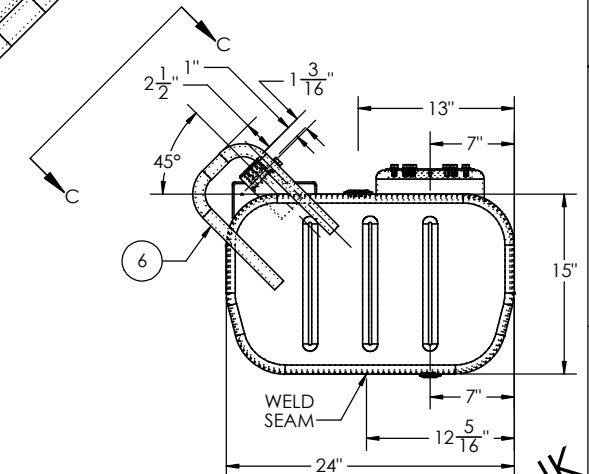
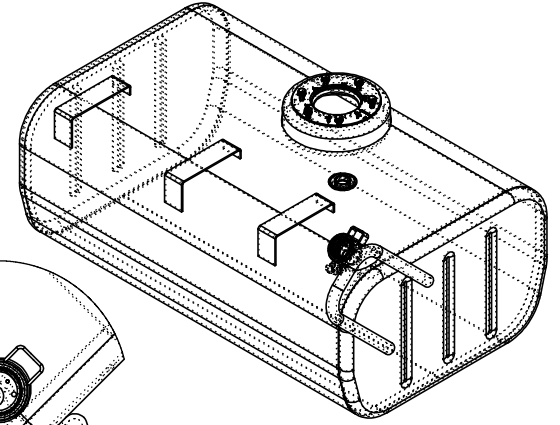

VIEWED FROM RIGHT
END OF TANK

GASOLINE TANK

ITEM NO.	PART NUMBER	DESCRIPTION	Default/ QTY.
1	BRL-AT-GM-4014	1/8" TANK BARREL	1
2	ECP-024038412500	15" X 24" MILGRADE ALUMINUM TAPERED BOTTOM END CAP	2
3	ADP-732220	MILGRADE ALUMINUM GMC DOME RISER PLATE (NEW)	1
4	FLG-050220	1/2" NPTF MILGRADE ALUMINUM FLANGE	1
5	CLP-2	GM UPPER STEP CLIP	3
6	FILL NECK GUARD	1" TUBING GUARD	1
7	FLN-096012210	6" LONG - MILGRADE ALUMINUM GASOLINE FILL NECK	1
8	MSC-026	MILGRADE ALUMINUM GASOLINE CAP TETHER BRACKET	1
9	FLG-070220	1" NPTF MILGRADE ALUMINUM FLANGE	1

TITLE:		UNLESS OTHERWISE SPECIFIED:		NAME	DATE
SIZE C	REV	QC	INITIALS	DRAWN	
		PSI		CHECKED	
		DIMS		ENG APPR.	
		PARTS		MFG APPR.	
		TAG		DIA.	
PKG		FINISH	SEE BOM	COMMENTS:	
<small>PROPRIETARY AND CONFIDENTIAL</small> <small>THE INFORMATION CONTAINED IN THIS DRAWING IS THE SOLE PROPERTY OF ALUMITANK. ANY REPRODUCTION IN PART OR AS A WHOLE WITHOUT THE WRITTEN PERMISSION OF ALUMITANK IS PROHIBITED.</small>		<small>DIMENSIONS ARE IN INCHES</small> <small>TOLERANCES:</small> <small>FRACTIONAL: ±</small> <small>ANGULAR: MACH ± BEND ±</small> <small>TWO PLACE DECIMAL</small> <small>THREE PLACE DECIMAL ±</small>		<small>11317 N. US HWY 14</small> <small>HARVARD, IL 60033</small> <small>815-943-6649</small>	
		<small>MATERIAL:</small> 5052 H32 ALUMINUM		<small>800-652-6630</small> <small>FAX 855-774-6918</small> <small>WWW.ALUMITANK.COM</small> <small>INFO@ALUMITANK.COM</small>	
		<small>INTERPRET GEOMETRIC TOLERANCING PER:</small>		<small>DWG. NO.</small> AT-GM-4014	
		<small>DO NOT SCALE DRAWING</small>		<small>SCALE: 1:8</small> <small>WEIGHT:</small> <small>SHEET 1 OF 2</small>	